

# Rainwater Harvesting Systems for Montana

by Gretchen Rupp, PE, Director: Montana Water Center  
updated by Ben Cichowski, EIT: Montana Water Center

Working with the people of Montana to design and implement innovative approaches to conserving our most precious resource.



## MontGuide

MT 199707 AG revised 11/06

### PEOPLE COLLECT AND STORE RAINWATER

throughout the world. On many inhabited islands, rain is the sole source of domestic water. In portions of the U.S. where groundwater and surface water are scarce, expensive or of poor quality, people use rainwater. Early farm and ranch families throughout the Great Plains routinely collected rainwater to use for laundry and other purposes.

Rainwater harvesting is no longer widely practiced in Montana, but it is a simple technology that offers many potential benefits. Collected rainwater can augment other water sources when they become scarce. It's a good standby in times of emergency, such as during power outages or when the water table lowers and wells go dry. Rainwater is soft and doesn't cause buildup of scale in water heaters, plumbing lines or household humidifiers. It does not compromise the effectiveness of pesticides when mixed in spray rigs, as eastern Montana groundwater often does. Rainwater does not stain laundry and plumbing fixtures (no iron or manganese). And it is better for landscape watering than waters that are naturally alkaline or rich in sodium.

Simple rainwater systems for landscape irrigation or herbicide application can be designed and installed by any homeowner. Systems designed to supply water for in-house use are far more sophisticated, but they too can be laid out by the homeowner. This guide describes the components of a rainwater system and the process of designing the system. The homeowner planning a system for outdoor use will find most of the needed information herein. Some rough guidelines for potable water systems are included, but additional resources must be consulted; an example is listed at the end of the guide.

### System Components

Each component in the rainwater system serves one of the following functions: rainwater catchment, conveyance, treatment (including disinfection if it is to be used for drinking water), storage or distribution. Figure 1 is a generalized schematic of a

rainwater system, showing examples of each system component.

**Catchment:** In special circumstances, paved patios or decks can be used to collect rainwater. Generally though, the available catchment area is the roof of the home, barn and outbuildings. Any roofing material is acceptable for collecting water for non-potable uses. Water to be used for drinking should not be collected from roofs covered with asphalt composite shingles, and lead flashing should not be used in these systems.

**Conveyance:** Gutters, downspouts and pipes convey roof runoff to the storage tank called the cistern. Gutters need to be sloped at least  $\frac{1}{16}$  inch per foot of run. They should be suspended from hangers no more than three feet apart. Aluminum or galvanized metal are recommended because of their sturdiness, although inexpensive plastic gutters may serve beneath small roof areas. The downspout should be sized to provide at least one

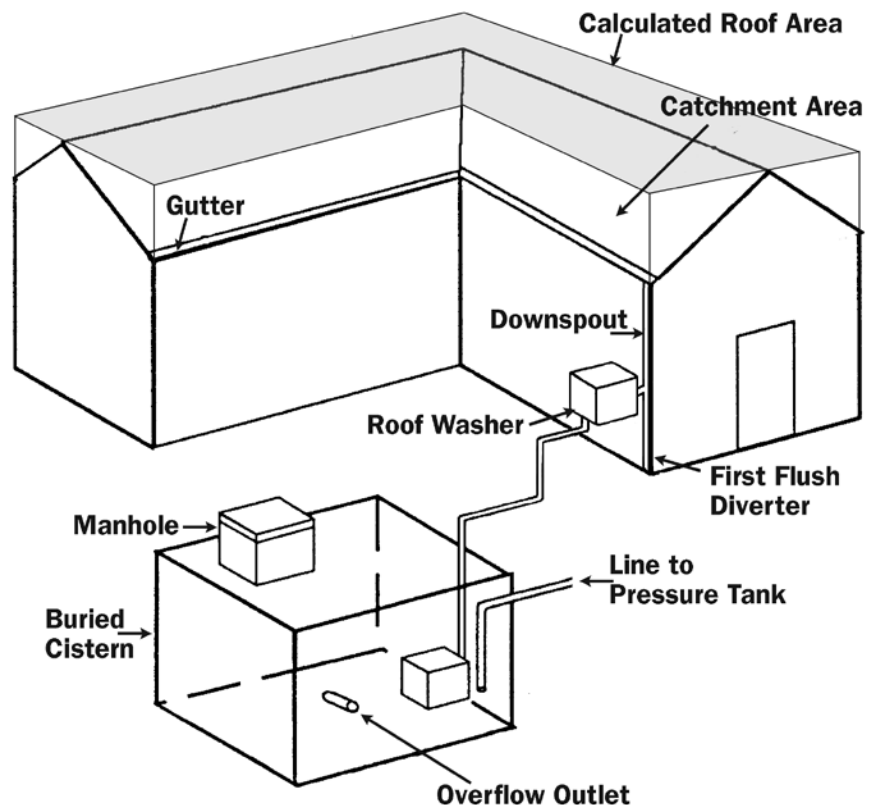

Figure 1. Basic rainwater harvesting system

square inch of opening per 100 square feet of roof area. Provide a downspout for each 50 feet of gutter run. If there are tall trees near the roof, cover the gutter with ½-inch hardware cloth, and place simple wire baskets in each downspout opening to keep leaves and twigs out of the runoff. The pipe leading to the cistern should be a minimum of 4 inches in diameter (assuming the most common layout – gravity flow). It need not be buried beneath the frost line, but must have a slope of at least ¼ inch per foot. Sharp pipe bends should be avoided, and cleanouts should be incorporated where horizontal runs exceed 100 feet.

**Treatment:** Dust, leaves and bird droppings accumulate on roof surfaces between rainstorms. A first flush diverter is often used to eliminate most of the contamination from the roof before the runoff reaches the cistern. A common first flush diverter is shown in Figure 2. Water will not begin to flow into the cistern until the diverter has filled completely. A trickle drain ensures an empty chamber for subsequent rainfall events. A good rule of thumb is to divert at least 10 gallons per 1000 square feet of catchment area. If you are constructing your own diverter from PVC pipe, Table 1 provides a quick reference for determining the length of your chamber. A roof washer should also be installed between the first flush diverter and the cistern. The roof washer contains a screen that will filter out large debris such as twigs and leaves. Various devices can be constructed by the homeowner or purchased commercially for this purpose. A common design is shown in Figure 3. If you plan on using your collection system for potable water, you will also want to include a 30 or 50 micron filter for preliminary filtration. Additionally, a disinfection device should be located within the home. This could be either a point-of-use device or an in-line unit treating all of the household water.

**Storage:** The cistern can be of nearly any size and material. A wood, metal or plastic barrel placed beneath a downspout during the warm months is all that's necessary for watering the front flowerbed. Conversely, a tank that is to hold the household water supply throughout the year may need a capacity of 10,000 gallons. Any cistern to be used throughout the year in Montana must be buried, preferably with its top beneath the frost line. Any watertight tank of non-toxic material will serve: bulk milk tanks, unused lined fuel tanks, or precast fiberglass, polyethylene or concrete tanks, including those designed as septic tanks. As in any application, only tanks designed to be installed underground should be buried. Large cisterns are often made of concrete cast in place. Lined or coated concrete-block vaults are not recommended, as it is very difficult to make them waterproof and structurally sound. The cistern inlet and outlet should be designed to minimize stirring the solids settled on the tank bottom, and the tank should include a manhole, a vent, a cleanout sump and an overflow pipe. If the cistern is to store potable water, a vertical fill pipe for use by water haulers is also desirable. Consult the listed references for design details.

**Distribution:** Except on steeply sloping hillsides, a pressurized system is needed to distribute the water from the

cistern. A ⅓ or ½ horsepower pump, coupled with a pressure tank, usually suffices. The outlet line from the cistern should be buried beneath the frost line.

Rainwater is naturally acidic, and corrosive to metal tanks and household plumbing. In homes where the water lines are copper joined with lead-containing solder, the rainwater should be neutralized before it enters the water lines to preventing mobilizing lead and copper into drinking water. This can be done with a commercially-available “neutralizing filter,” or by adding crushed limestone as the filter media.

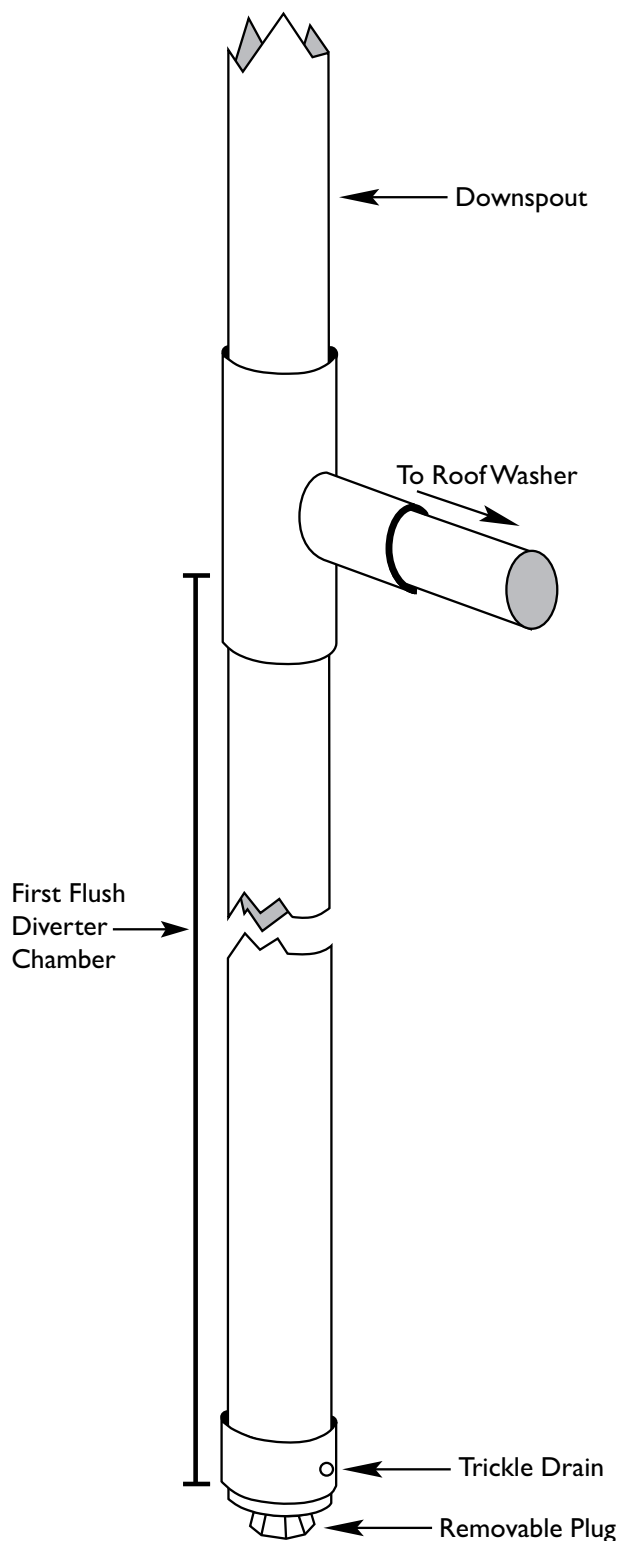

Figure 2. Basic first flush diverter design

Table 1. Calculating the length of your first flush diverter chamber

PVC Pipe Diameter (Inches)	Chamber Length (Inches/Gallon)
3"	32.75"
4"	18.5"
6"	8.25"
8"	4 5/8"

## Design Approach

The design of an individual rainwater harvesting system depends on the planned water use, the layout of the yard or farmstead, and the reliability of the water supply that is needed. Different approaches are taken in different parts of the country. For Montana homeowners, the following steps are suggested: estimate whether rainwater could satisfy the identified need; decide on the needed reliability of the supply; size and locate the catchment area; size and design the cistern; select, locate and size the appurtenances.

**Estimate Rainwater Availability:** In theory, about six-tenths of a gallon of water is produced by one inch of rainfall on one square foot of roof area. Roughly 35 percent of the precipitation that falls on a Montana roof is unavailable for use because of evaporation, leakage or diversion by the roof washer. Based on this yield estimate, Equations 1 and 2 (below) show the amount of water that can be harvested from a given roof area for a given amount of precipitation. As the equations show, one inch of precipitation falling on one square foot of roof area yields four-tenths of a gallon of usable water (the factors 0.4 and 2.5 convert among inches, feet and gallons). The first step is to estimate the annual water needs in gallons, and use Equation 2 to decide whether the available catchment area could meet the need. For making up herbicide solution, base your estimate on your own experience. Estimate landscape irrigation-water requirements from Extension Service guidance. In-home water use ranges from 30 gallons per person per day (low-flow plumbing fixtures, laundering of full loads only, no use of a garbage grinder, showers rather than baths) to 100 gallons per person per day (no consideration given to water conservation).

**Establish Needed Reliability:** If rainwater is to be used only as a high-quality supplement to plentiful groundwater, it is not crucial to collect a rainwater volume equal to the water need every single year. In this case you can size your system based on your average annual precipitation. Each year the precipitation is less than average, you need to use some groundwater.

The reason for designing a system that you know will not meet your needs every year is to save money – large cisterns are very expensive. Conversely, if the rainwater is to be the sole source of drinking water for your family, you must size the system so that it collects and stores enough water even during drought years. In this case, basing your design on an annual precipitation value of 50% of average is suggested.

**Size and Locate Catchment Area:** The pertinent catchment area is calculated from Equation 2. Catchment area should be calculated based on the footprint created by the roof (Figure 1), and not by the square footage of the roof surface. An excessively steep catchment area or a dramatic rainfall event may further decrease capture estimates due to gutter overflow. Be sure to use roof surfaces as near as possible to the planned cistern location, to shorten pipe runs. If you have the option, you may wish to avoid roofs with a northern aspect: ice buildup may make it very difficult to maintain gutters there (heat tape may prevent this problem).

**Size and Design the Cistern:** Because precipitation and water

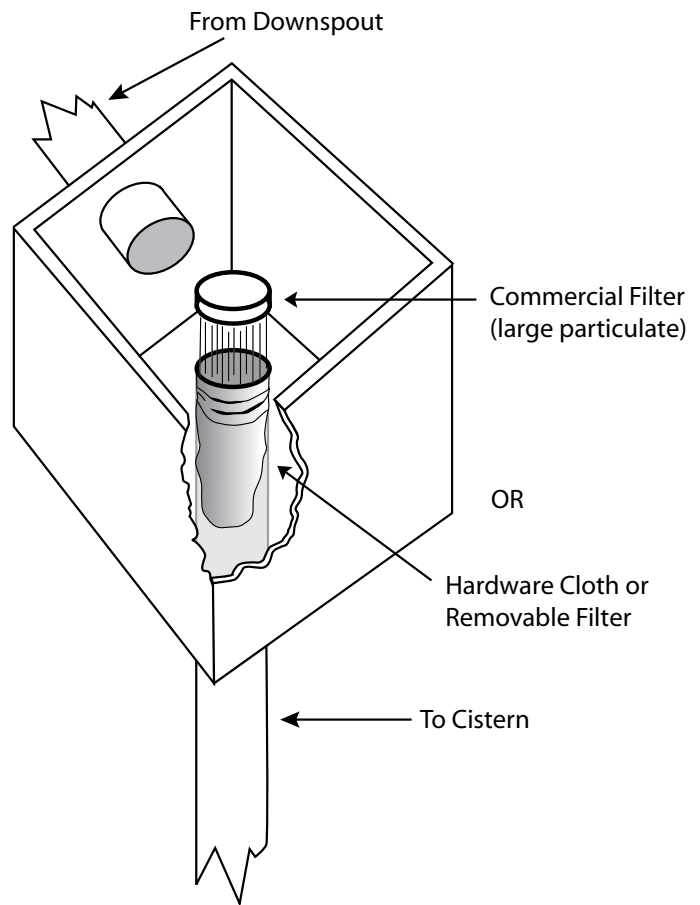

Figure 3. Basic roof washer design

demand are very uneven over the course of the year (except for in-home demand), the cistern cannot be sized on the basis of annual precipitation and demand. Instead, the total demand during the dry months must be estimated; this is the volume that must be in storage at the beginning of the dry season (generally July 1). Monthly average precipitation values are needed for this exercise; these can be obtained from MSU Extension Bulletin 113, Climate Atlas of Montana.

If the needed storage volume is 5000 gallons or less, a lightweight fiberglass, metal or polyethylene tank will be possible. Their advantage is that they can be transported to your site and lowered into place by smaller, lighter equipment, and they do not leach alkalinity into the water, as concrete does. On the other hand, they do not have the bearing strength of concrete tanks. This is important if the tank is to be buried deeply, or beneath the driveway or farmyard.

**Select, Locate and Size Appurtenances:** A 1-inch or 1.25-inch pipe is generally used for conducting water from the cistern to the service pump and pressure tank. The cistern's overflow pipe should be as large as the inlet pipe from the downspouts.

If the rainwater is to be used within the house, special care must be taken to prevent its contamination. The cistern itself, as well

$$G = 0.4XRXA$$

**Equation 1**

where

G = gallons of water harvested

R = precipitation, inches of water

$$A = 2.5 \times G / R$$

**Equation 2**

A = roof area, square feet

as each fitting, must be leak proof. Manhole risers and vent pipes emerging from a buried system should end at least eight inches above the ground surface, so that surface water can never flow down into the cistern. The cistern should be located uphill and at least 100 feet from the nearest point of the septic system. Avoid potential cross-connections: never plumb any part of the rainwater system (including the cistern overflow) into the wastewater lines so that suction could draw sewage into the system.

## Costs

The most expensive part of the rainwater system is usually the cistern. Water tanks with a capacity of 2000 gallons or less cost between \$0.30 and \$1.10 per gallon of storage; concrete tanks are more expensive than equivalent synthetic tanks. The cost of concrete construction can vary greatly, but is usually between \$70 and \$100 a yard plus labor. Hiring a contractor to install a large, heavy tank on a remote farmstead is also expensive; call local contractors for estimates. A cast-in-place cistern may be an option for some situations. For large cisterns, this approach may be cheaper than bringing a precast tank onto the site.

### Example: Designing a System

John Riley wishes to collect precipitation to water a young shelterbelt that covers 1500 square feet. The county Extension agent tells him he should apply an inch of water to the shelterbelt each week between June 15 and Sept. 15, and that the average rainfall during that time is two inches. John calculates that he will need to collect 9,350 gallons (see example calculation below) to water the shelterbelt each summer. After pricing cistern options, he decides he only wishes to buy 6000 gallons of storage capacity, and will use well water for the rest of his irrigation water. For a catchment area, he will need at least

$$A = 2.5 \times 6000 \text{ gallons} / R\text{-annual} \quad (\text{Equation 2})$$

where R-annual is the total average annual precipitation, in inches. The average annual precipitation on the Riley place is 15 inches, so John will need to collect from a roof area with a horizontal projection of at least 1000 square feet ( $2.5 \times 6000/15$ ). He decides to collect from the south side of his barn, which has 1200 square feet of roof area and is just above where he wishes to install his cistern.

## Maintenance

If the rainwater is to be used for drinking water, the inside of the finished cistern should be scrubbed down with a 10 percent bleach solution and rinsed thoroughly before the system is put in use. The cistern will need to be drained and emptied of accumulated sediment every few years. At that time, cracks should be patched with a non-toxic sealant. Be sure to employ vigorous, positive ventilation when working inside the tank.

Other system maintenance is straightforward: keep gutters and downspouts clean and in good repair; clean the first flush diverter and roof washer at least once a year; and service pumps periodically.

## Resources

### General

Harvested Rainwater, 1996. Austin, Texas Green Builder's Sourcebook. Website <http://www.greenbuilder.com/sourcebook/rainwater.html>

Yard and Garden Water Management. 1993. MontGuide 8915 AG, MSU Extension Service, Bozeman, MT

The Texas Manual on Rainwater Harvesting. Third Edition 2005. Texas Water Development Board. Austin, Texas. Website [http://www.twdb.state.tx.us/publications/reports/RainwaterHarvestingManual\\_3rdedition.pdf](http://www.twdb.state.tx.us/publications/reports/RainwaterHarvestingManual_3rdedition.pdf)

### Drinking Water Systems

Private Water Systems Handbook, MWPS-14. 1979. Midwest Plan Service, Ames, IA.

Captured Rainfall; Small-Scale Water Supply Systems. 1981. California Dept. of Water Resources Bulletin 213. \$1 from CA DWR; PO Box 942836; Sacramento, CA. 94236-0001.

Rainwater Cisterns: Design, Construction and Water Treatment. 1989. E.S. Young and W.E. Sharpe. Penn State College of Agriculture Cooperative Extension, Circular 277 University Park, PA. (814) 865-7685.

Household Drinking Water Protection and Treatment. 1991. M. Vogel. MSU Extension Bulletin EB 102. (\$3.50) Bozeman, MT. (406) 994-3273.



<http://www.montana.edu/wwwpb/pubs/mt199707.html>

Copyright © 2006 MSU Extension Service

We encourage the use of this document for nonprofit educational purposes. This document may be reprinted for nonprofit educational purposes if no endorsement of a commercial product, service or company is stated or implied, and if appropriate credit is given to the author and the MSU Extension Service. To use these documents in electronic formats, permission must be sought from the Extension Communications Coordinator, Communications and Public Affairs, 416 Culbertson Hall, Montana State University-Bozeman, Bozeman MT 59717; **E-mail: [publications@montana.edu](mailto:publications@montana.edu)**. To order additional publications, please contact your county or reservation MSU Extension office, visit our online catalog at [www.montana.edu/publications](http://www.montana.edu/publications), or **e-mail [orderpubs@montana.edu](mailto:orderpubs@montana.edu)**



The U.S. Department of Agriculture (USDA), Montana State University and the Montana State University Extension Service prohibit discrimination in all of their programs and activities on the basis of race, color, national origin, gender, religion, age, disability, political beliefs, sexual orientation, and marital and family status. Issued in furtherance of cooperative extension work in agriculture and home economics, acts of May 8 and June 30, 1914, in cooperation with the U.S. Department of Agriculture, Douglas L. Steele, Vice Provost and Director, Extension Service, Montana State University, Bozeman, MT 59717.

**File under: Water Resource Mgmt.**

**C-1 (Structures)**

**Revised November 2006  
1000-08/06JM**