

PRE-ASSEMBLED. INTEGRATED. FIBERGLASS. FILTRATION VAULT.



The RainFlo integrated filter and vault system is a single unit that provides an optimal pre-filtration solution for underground rainharvesting and storm-water management applications. The fiberglass vault is compact and can be rotated 360° in relation to the storage tank, simplifying installation. The vault houses the high performance GRAF Optimax XXL filter capable of flow rates over 6000 GPM. The Optimax XXL features self-cleaning spray heads and a stainless steel filter insert that reduces maintenance. The lightweight fiberglass construction makes installation easier and shipping cost effective.

Key Benefits:

- Omni-directional filter connection points simplify installation
- Vault and Optimax XXL system ships fully assembled and ready to mount to any fiberglass, steel, plastic, or concrete tank reducing installation time
- Integrated filter and vault system reduces plumbing connections
- Combining access points to one location utilizes available space efficiently
- Assembly directly mounted to tank reduces overall installation footprint
- No external vault required

ORDERING INFORMATION

Part Number	Description
340096FRPVAULT10	Fiberglass filter vault with Optimax XXL filter, 10" connection
340096FRPVAULT12	Fiberglass filter vault with Optimax XXL filter, 12" connection
340096FRPVAULT16	Fiberglass filter vault with Optimax XXL filter, 16" connection

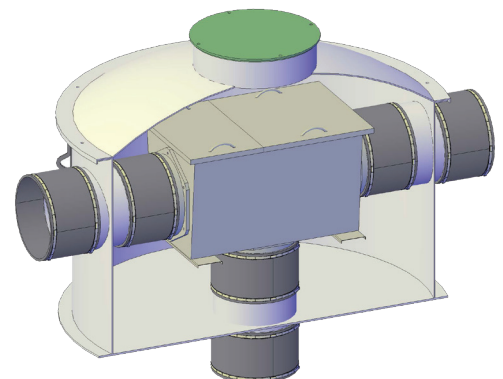

DIMENSIONS

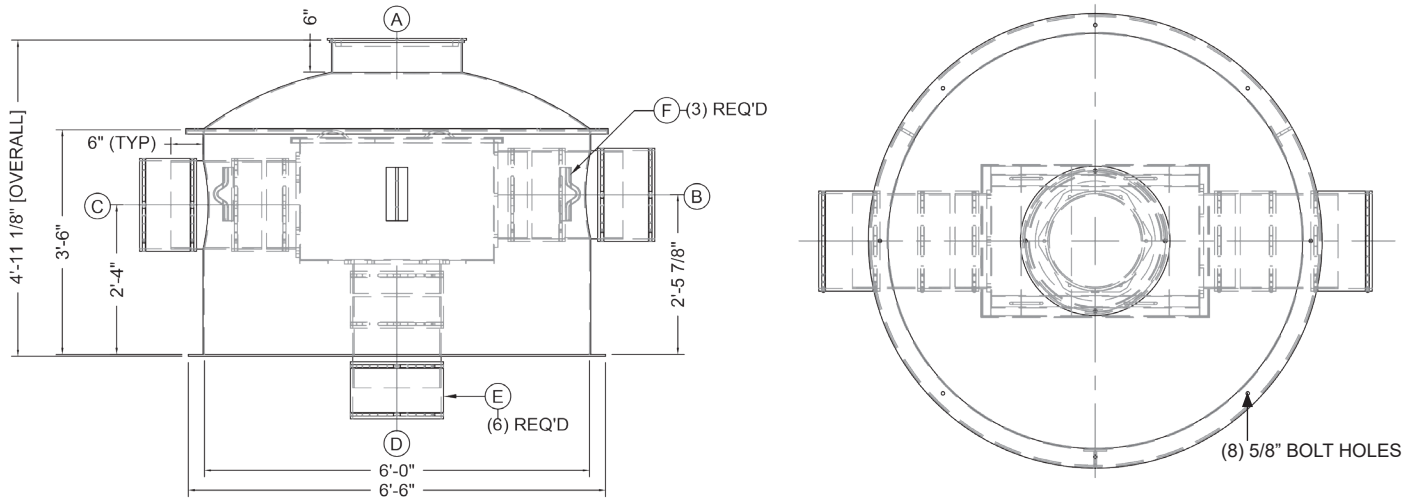

INSTALLATION

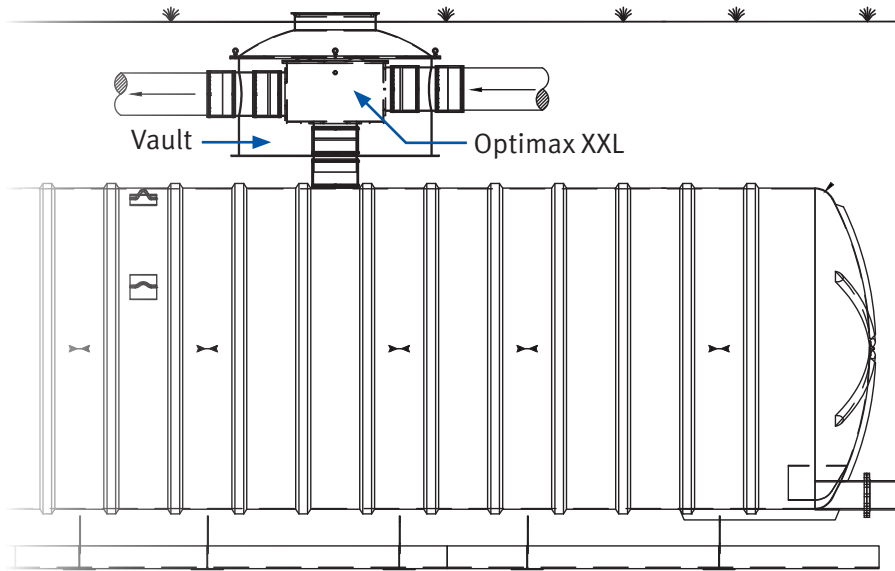

The RainFlo integrated filter and vault is a pre-assembled, single unit that mounts directly to the top of a fiberglass tank. The unit ships complete with the tank.

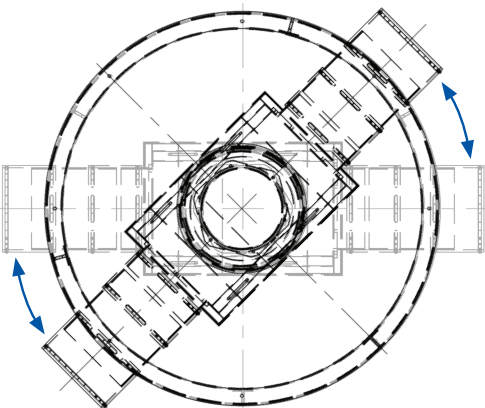

The vault can be rotated 360° in relation to the storage tank, making it easier to install.