

MAXIMUM WATER YIELD. LOW MAINTENANCE. WATER FILTRATION.

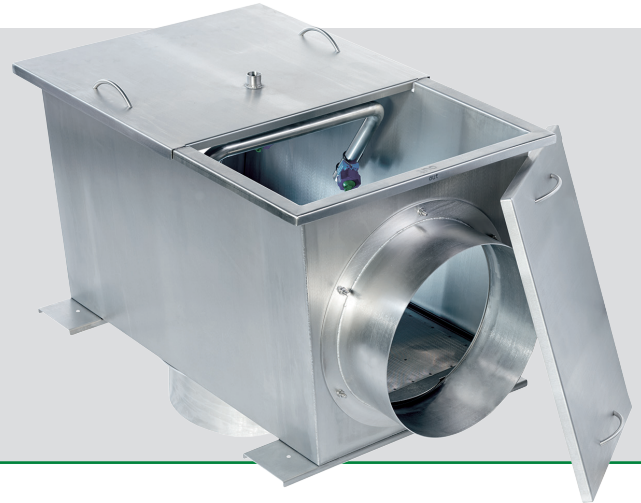

The GRAF Optimax XXL pre-filter is the professional choice for large scale commercial and industrial rainwater harvesting systems. Available with 10", 12", and 16" pipe connections sizes, the Optimax XXL is capable of processing higher inlet flows at higher efficiency than any other rainwater harvesting pre-filter in the world. The Optimax XXL filter features integrated filter spray heads for cleaning the 350 micron pre-filtration screen, making the Optimax XXL nearly maintenance free.

Features:

- All stainless steel construction with 0.01" mesh filter insert
- Water yield of over 95%, up to 90% efficient at ~3800 GPM
- 10", 12", and 16" connection sizes available
- Suitable for above and below ground installation
- Bolt on lid
- Patented filter technology
- Self-cleaning filter principle
- Cleaning unit included
- Height loss of just 1.75" between inlet and dirty water outlet
- Available with fiberglass installation vault

ORDERING INFORMATION

Part Number	Description
340096	Optimax XXL external filter housing
340104	10" connection kit
340098	12" connection kit
340100	16" connection kit

FILTER CLEANING UNIT

The Optimax XXL filter cleaning unit consists of four adjustable flat jet nozzles with a very powerful water jet to clean the filter screen. This means fewer maintenance intervals.

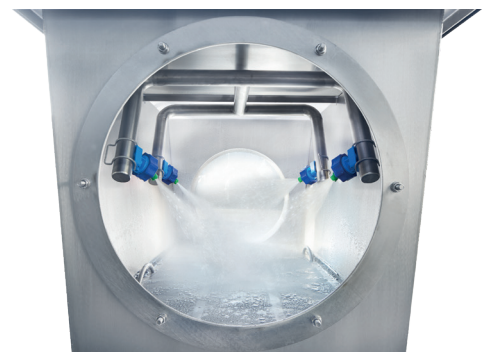

DIMENSIONS

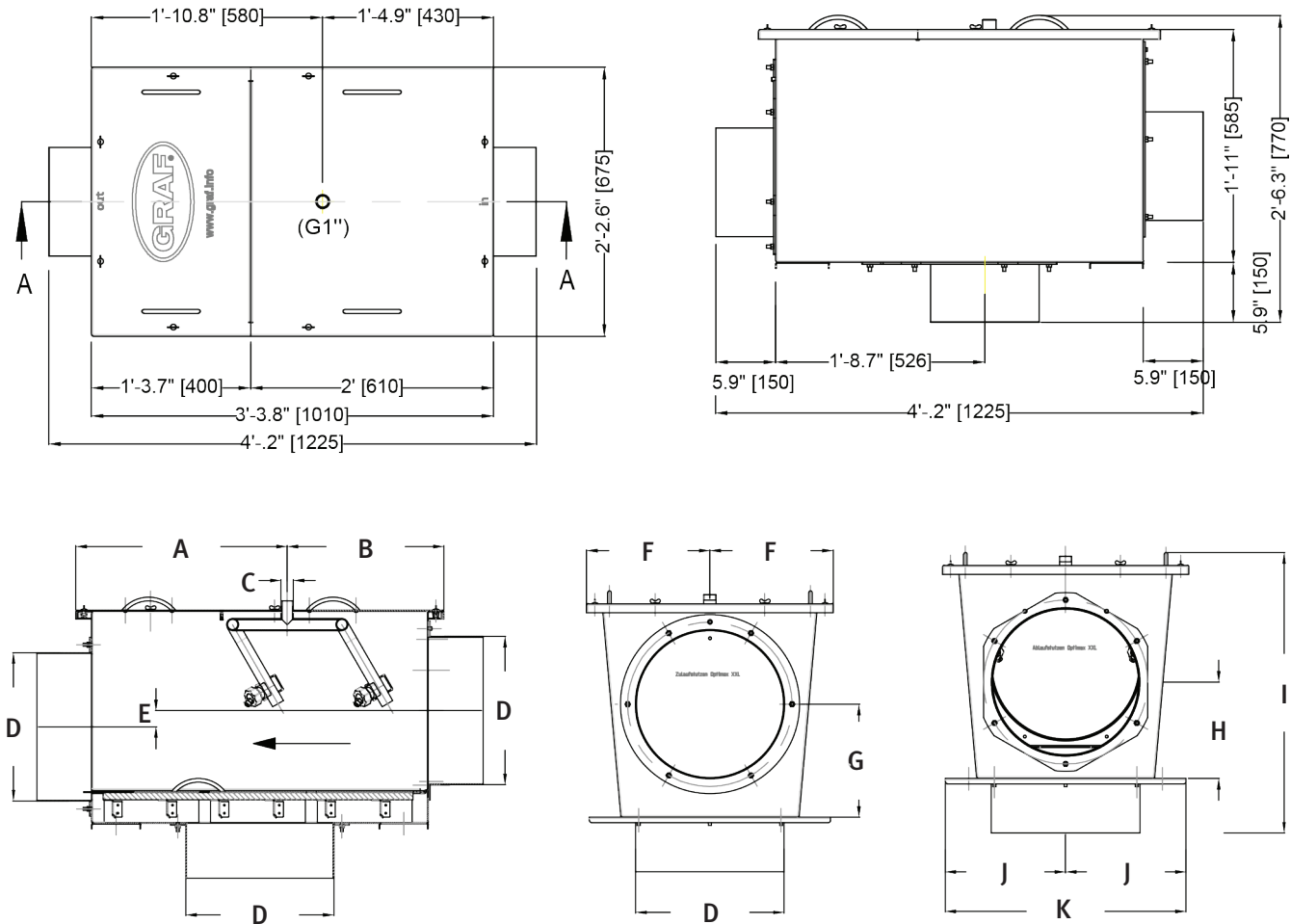

Connection	A	B	C	D	E	F	G	H	I	J	K
10" (250)	22.8" (580)	16.9" (430)	1" (25)	10.7" (273)	1.6" (41)	13.3" (338)	9.5" (242)	7.9" (201)	30.3" (770)	13.0" (330)	26.0" (660)
12" (300)	22.8" (580)	16.9" (430)	1" (25)	12.8" (324)	1.8" (45)	13.3" (338)	10.5" (268)	8.9" (226)	30.3" (770)	13.0" (330)	26.0" (660)
16" (400)	22.8" (580)	16.9" (430)	1" (25)	16.0" (406)	1.8" (45)	13.3" (338)	12.2" (309)	10.4" (265)	30.3" (770)	13.0" (330)	26.0" (660)

Dimensions are for reference only.

FIBERGLASS VAULT OPTION

The RainFlo integrated GRAF Optimax XXL filter and vault system is a single unit that provides an optimal pre-filtration solution. The system ships fully assembled and ready to mount to any fiberglass, steel, plastic, or concrete tank reducing installation time. The fiberglass vault is compact and can be rotated 360° in relation to the storage tank, simplifying installation.

