

Installation and maintenance instructions for PLATIN XXL Rainwater Underground Tank

PLATIN XXL 20.000 - 65.000 l

Order No.:

20000 l: 391000 (391810+371018+371065)

25000 l: 391001 (391811+371018+371065)

30000 l: 391002 (391812+371018+371065)

35000 l: 391003 (391813+371018+371065)

40000 l: 391004 (391814+371018+371065)

45000 l: 391005 (391815+371018+371065)

50000 l: 391006 (391816+371018+371065)

55000 l: 391007 (391817+371018+371065)

60000 l: 391008 (391818+371018+371065)

65000 l: 391009 (391819+371018+371065)

PLATIN XXL infiltration tank

20.000 – 65.000 l: 391450 - 391459

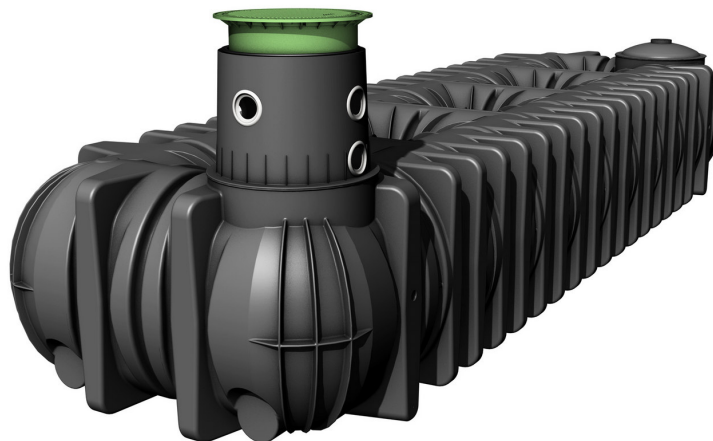

The points described in these instructions must be observed under all circumstances. All warranty rights are invalidated in the event of non-observance. Separate installation instructions are enclosed in the transportation packaging for all additional articles purchased from GRAF.

Missing instructions must be requested from us immediately.

The tank must be checked for any damage prior to insertion into the trench under all circumstances.

Missing instructions can be downloaded on www.graf.info or can be requested from GRAF.

Table of contents

1. GENERAL NOTES	2
1.1 Security	2
1.2 Identification obligation	2
2. INSTALLATION CONDITIONS	3
3. TECHNICAL DATA	4
3.1 Technical Data Platin XXL	4
3.2 Overview tanks Platin XXL	4
4. TANK STRUCTURE	5
5. INSTALLATION AND ASSEMBLY	5
5.1 Construction site	6
5.2 Trench	6
5.3 Insertion and filling	8
5.4 Routing connections	8
6. ASSEMBLING THE TANK DOME TELESCOPIC DOME SHAFT	9
6.1 Assembling the tank dome	9
6.2 Assembling the telescopic dome shaft	9
6.3 Telescopic dome shaft on which persons may walk	9
6.4 Telescopic dome shaft over which passenger cars may drive	9
6.5 Telescopic dome shaft for HGV loading	10
7. ASSEMBLY OF THE ADAPTER	10
7.1 Assembling the extension	10
8. PLATIN XXL INFILTRATION TANK	11
8.1 Platin XXL Infiltration Tank	11
8.2 Installation and assembly	11
8.3 Preparing and shortening the drainage pipes	11
8.4 Assembling the drainage accessories	12
8.5 Filling	12
8.6 Laying connections and fitting the cover	12
9. INSPECTION AND SERVICING	13

1. General notes

1.1 Security

The relevant accident prevention regulations according to BGV C22 must be observed during all work. Particularly when walking on the tanks, a 2nd person is required to secure the tank.

The relevant regulations and standards must additionally be taken into consideration during installation, assembly, servicing, repair, etc. Relevant notes can be found in the corresponding sections of these instructions.

During all work on the system or parts of the system, the entire system must always be rendered inoperable and secured to prevent unauthorised reactivation.

Except in the event of work carried out in the tank, the cover of the tank must always be kept sealed, as this otherwise constitutes a maximum risk of accident. The rain protection installed on delivery is merely transportation packaging. It cannot be walked on and is not child-proof; it must be replaced with a suitable cover immediately following delivery (telescopic dome shaft with corresponding cover)!

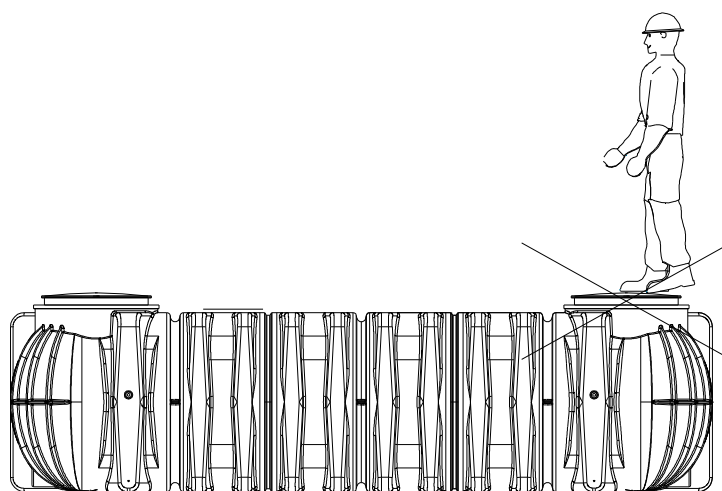

Only original GRAF covers or covers approved in writing by GRAF must be used.

GRAF offers an extensive range of accessories, all of which are designed to match each other and which can be extended to form complete systems. The use of accessories that have not been approved by GRAF results in the exclusion of the warranty/guarantee.

1.2 Identification obligation

All service water pipes and outlets must be identified in writing with the words "**Not drinking water**" or in the form of images (DIN 1988 Part 2, Para. 3.3.2.) in order to avoid inadvertent connection with the drinking water mains even after a number of years. Mix-ups, e.g. by children, may still occur even in the case of correct identification. All service water extraction points must therefore be installed with valves with **child-proof locks**.

2. Installation conditions

Coverage heights with telescopic dome shaft in green areas.

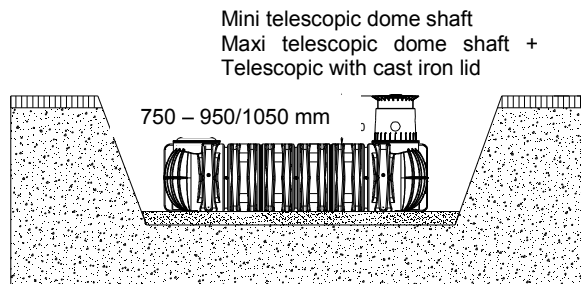

Maximum coverage heights with extension and telescopic dome shaft.

(in green areas only – not under passable areas)

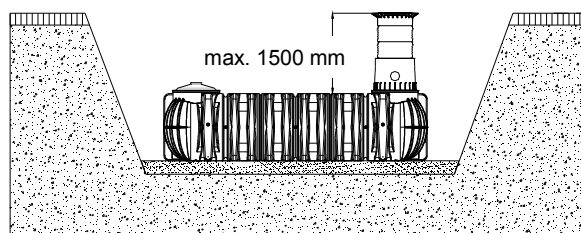

Cover heights with cast iron telescopic dome shaft (class B) in area driven over by vehicles up to 3.5 tonnes.

(without groundwater and stratum water)

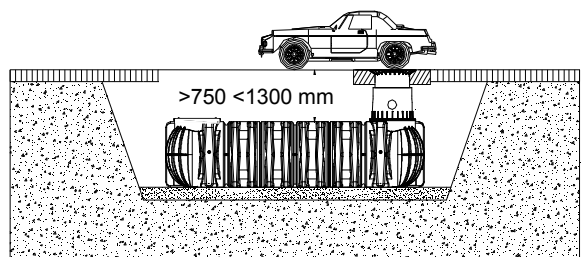

Cover heights with HGV-bearing telescopic dome shaft

(with cover class D – provided by customer), in area driven over by HGVs.

(without groundwater and stratum water)

Please note: HGV can only be driven over if a self-supporting, (Steel)-reinforced concrete plate is installed

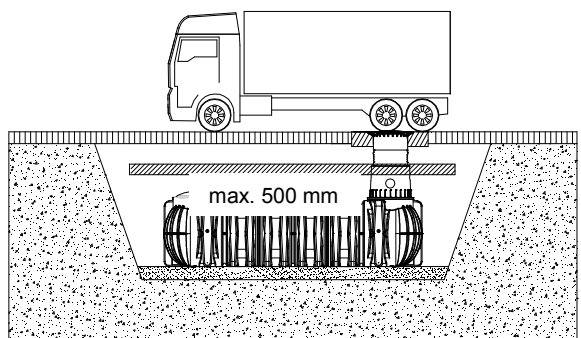

Coverage heights on installation in groundwater – the hatched area specifies the permissible immersion depth for the tank.

(not under passable areas)

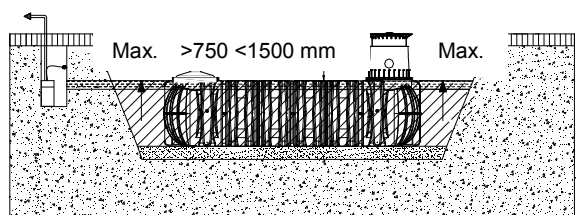

3. Technical data

3.1 Technical Data Platin XXL

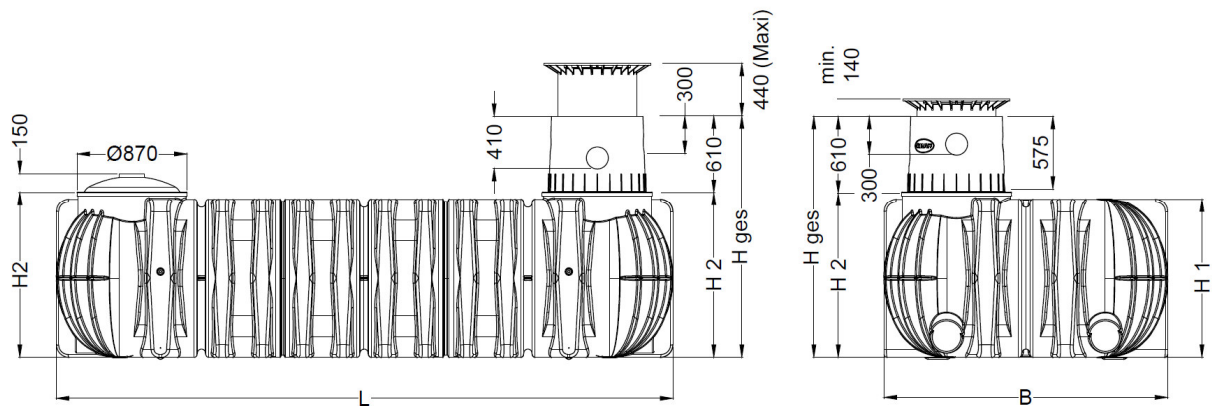

3.2 Overview tanks Platin XXL

Tank	20.000 L	25.000 L	30.000 L	35.000 L	40.000 L
Art. No.	391000	391001	391002	391003	391004
Weight	890 kg	1105 kg	1355 kg	1570 kg	1750 kg
L	9405 mm	11665 mm	14265 mm	16510 mm	18430 mm
W	2250 mm	2250 mm	2250 mm	2250 mm	2250 mm
H ₁	1250 mm	1250 mm	1250 mm	1250 mm	1250 mm
H ₂	1300 mm	1300 mm	1300 mm	1300 mm	1300 mm
Htot*	1910 mm	1910 mm	1910 mm	1910 mm	1910 mm

Tank	45.000 L	50.000 L	55.000 L	60.000 L	65.000 L
Art. No.	391005	391006	391007	391008	391009
Weight	2000 kg	2180 kg	2395 kg	2645 kg	2825 kg
L	21030 mm	22935 mm	25195 mm	27795 mm	29700 mm
W	2250 mm	2250 mm	2250 mm	2250 mm	2250 mm
H ₁	1250 mm	1250 mm	1250 mm	1250 mm	1250 mm
H ₂	1300 mm	1300 mm	1300 mm	1300 mm	1300 mm
Htot*	1910 mm	1910 mm	1910 mm	1910 mm	1910 mm

* Htot = total height

4. Tank structure

① Cover

② Telescopic dome shaft
(can be inclined by 5°)

③ Profile seal

④ Tank dome
(can be rotated by 360°)

⑤ Tank seal-Tank dome

⑥ Tank dome sealing plug

⑦ Platin XXL tank

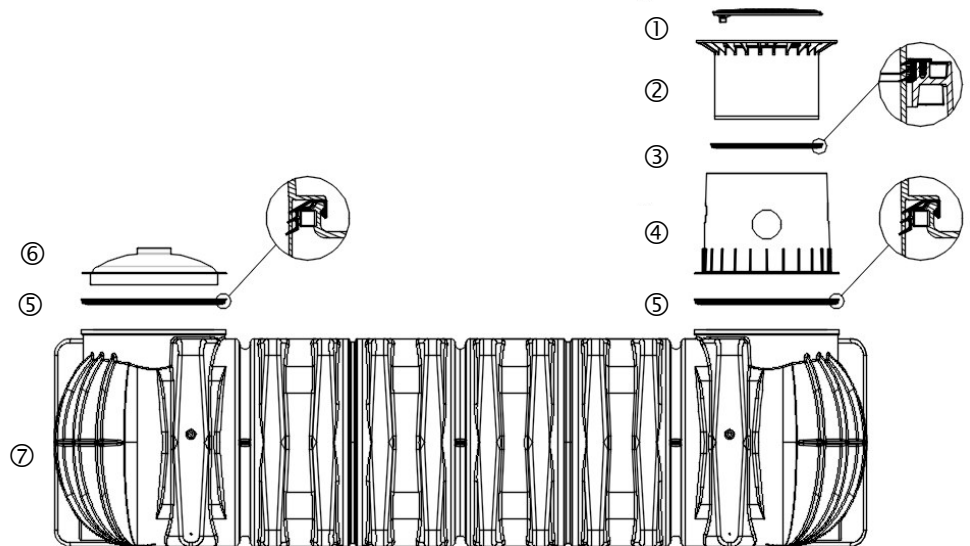

5. Installation and assembly

① Subsoil

② Telescopic dome shaft

③ Compacted foundation

④ Surrounding (round-grained gravel, max. grain size 8/16)

⑤ Covering layer

⑥ PLATIN XXL Rainwater Underground Tank

⑦ Concrete layer for passable surfaces

β --> DIN 4124 from 1250 mm depth of the trench

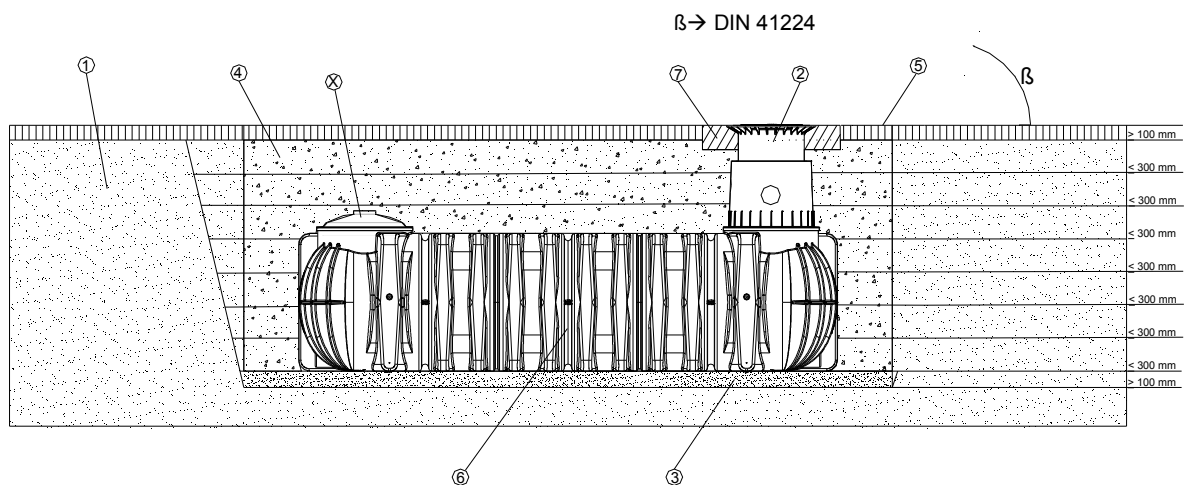

5. Installation and assembly

5.1 Construction site

Under all circumstances, the following points must be clarified prior to installation:

- The structural suitability of the ground according to DIN 18196
- Maximum groundwater levels which occur and drainage capability of the subsoil
- Types of load which occur, e.g. traffic loads

An expert ground report should be requested from the local planning authority to determine the physical characteristics of the subsoil.

5.2 Trench

To ensure that sufficient space is available for working, the base area of the trench must exceed the dimensions of the tank by > 100 mm on each side; the distance from solid constructions must be at least 1000 mm.

If the depth of the trench is > 1250 mm an embankment must be designed according to DIN 4124. The construction site must be horizontal and plane and must guarantee sufficient load-bearing capacity.

The depth of the trench must be dimensioned so that the max. earth coverage (see point 2 – installation conditions) above the tank is not exceeded. To use the system throughout the entire year, it is necessary to install the tank and those parts of the system which conduct water in the frost-free area. The frost-free depth is usually approx. 600 mm – 800 mm; precise information in this regard can be obtained from the responsible authority.

A layer of compacted, round-grain gravel (grain size 8/16, thickness approx. 100 - 150 mm) is applied as the foundation.

5.2.1 Slope, embankment, etc.

On installation of the tank in the immediate vicinity (< 5 m) of a slope, earthen mound or slope, a statically calculated supporting wall must be erected to absorb the soil pressure. The wall must exceed the dimensions of the tank by at least 500 mm in all directions, and must be located at least 1000 mm away from the tank.

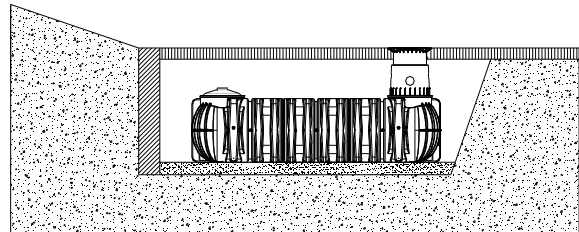

5.2.2 Groundwater and cohesive (water-impermeable) soils (e.g. clay soil)

If it is anticipated that the tanks will be immersed deeper into the groundwater than is shown in the adjacent figure, sufficient dissipation must be ensured. (See table for max. immersion depth). Dissipation of the drainage water (e.g. via an annular drainage system) is recommended in the case of cohesive, water-impermeable soils.

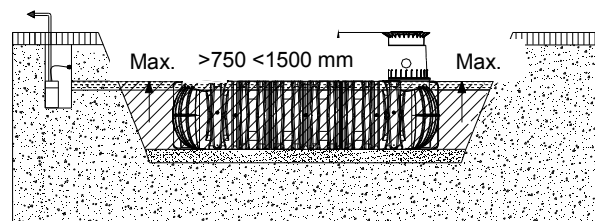

Tank	20.000 l - 65.000 l
max. immersion depth	1250 mm

5. Installation and assembly

5.2.3 Installation below HGV-bearing surfaces

The shaft can only be driven over with HGV in conjunction with a self-supporting, iron-reinforced concrete plate. To ensure that no additional forces or effects of HGV-bearing are transferred to the tanks, the dimensions and strength of the concrete plate must be statically calculated.

If you have any questions in this regard, please contact your GRAF-Team.

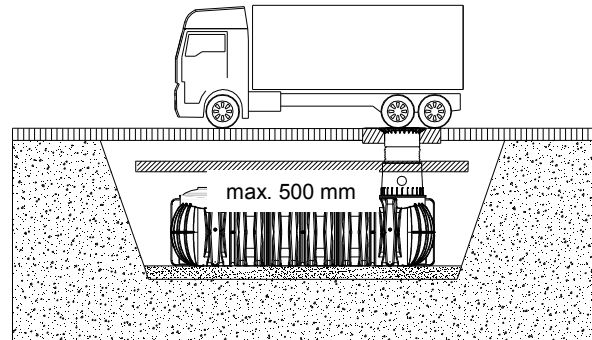

5.2.4 Installation adjacent to surfaces used by vehicles

If the underground tanks are installed adjacent to surfaces which are used by heavy vehicles weighing over 3,5 t, the minimum distance away from these surfaces is at least the depth of the trench.

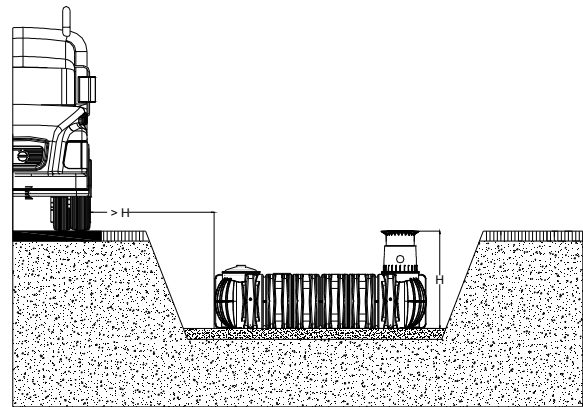

5.2.5 Connection of several tanks

Two or more tanks are connected via the assembly surfaces by means of GRAF special seals and basic pipes (to be provided at construction site).

The apertures must be drilled to the corresponding size using only the GRAF special crown bit. It must be ensured that the distance between the tanks is at least 600 mm. The pipes must project at least 200 mm into the tanks.

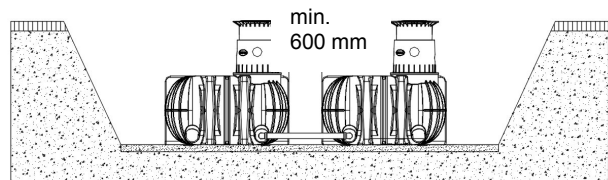

5. Installation and assembly

5.3 Insertion and filling

The tanks must be inserted, impact-free, into the prepared trench using suitable equipment. To avoid deformities, the tank is filled 1/3 with water before filling in the tank surrounding.

Afterwards the surrounding (roundgrain gravel, max. grain size 8/ 16) is then filled in layers of max. 30 cm steps and is compacted.

The individual layers as well as the medial support column must be well-compacted (manuel tamper). Damage to the tank must be avoided during compaction. Mechanical compaction machines must not be used under any circumstances. The surrounding towards the trench must be at least 100 mm wide.

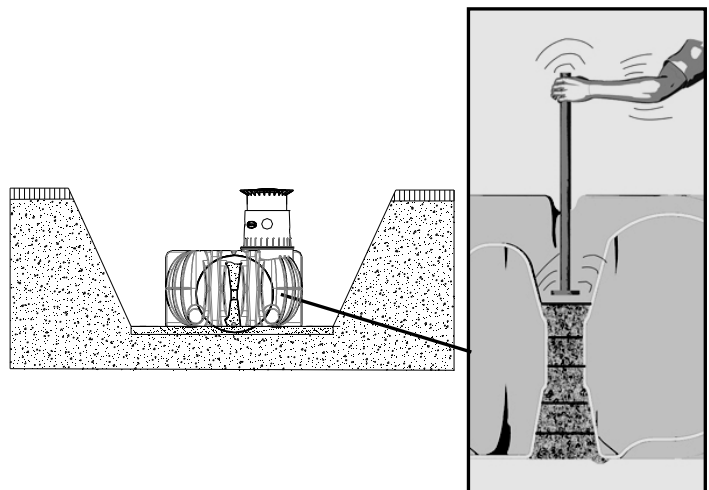
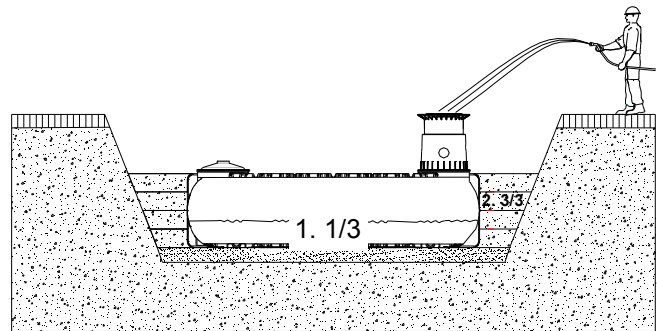

5.4 Routing connections

All feed and overflow pipes must be routed with a decline of at least 1 % in the direction of flow (possible, subsequent settling must be taken into consideration in this case). If the tank overflow is connected to a public sewer, this must be protected against reflux by means of a lifting station (mixed sewer) or reflux seal (pure rainwater sewer) according to DIN 1986.

All suction, pressure and control lines must be routed in an empty pipe, which must be routed as straight as possible, without bending, to the tank with a decline. Necessary bends must be formed using 30° moulded sections.

Important: The empty pipe must be connected to an aperture **above** the max. water level.

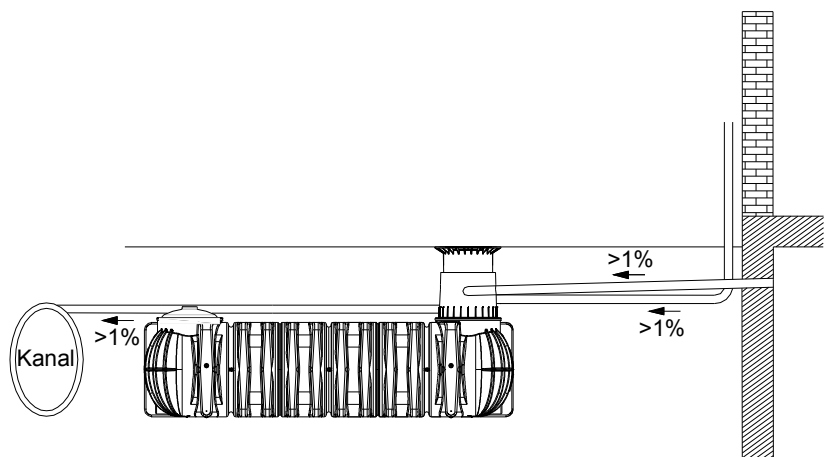

6. Assembling the tank dome telescopic dome shaft

6.1 Assembling the tank dome

Prior assembly, the enclosed seal is locked onto the tank neck's profile „B“. The tank dome is then locked to the tank neck. It is essential to make sure that the upper seal "A" (pre-assembled) is correctly installed.

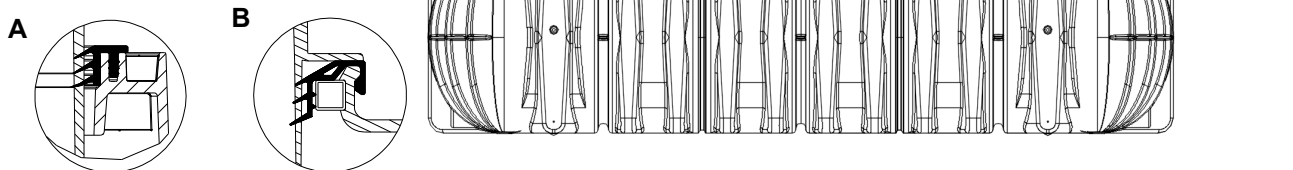

6.2 Assembling the telescopic dome shaft

The telescopic dome shaft enables infinite adaptation of the tank to given site surfaces with earth coverage of between 750 mm and 950 mm (Mini telescopic dome shaft) or 750 mm and 1050 mm (Maxi telescopic dome shaft).

For assembly purposes, the enclosed profile seal (material EPDM) is inserted into the tank dome's sealing groove and is coated generously with soft soap (do not use mineral oil-based lubricants, as these attack the seal). The telescope is then greased, inserted and aligned with the surface of the site.

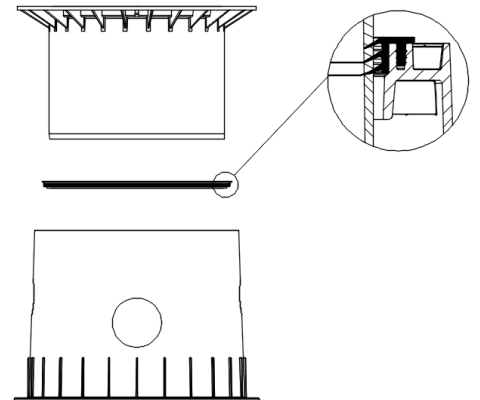

6.3 Telescopic dome shaft on which persons may walk

Important: To prevent loads from being transferred onto the tank, round-grain gravel ② (max. grain size 8/ 16) is filled in layers around the telescope ① and is evenly compacted. Damage to the tank dome ③ and telescope must be avoided during this step. The cover is then positioned and is sealed to prevent entry by children. **Tighten the threaded connection on the cover so tightly that it cannot be opened by a child!**

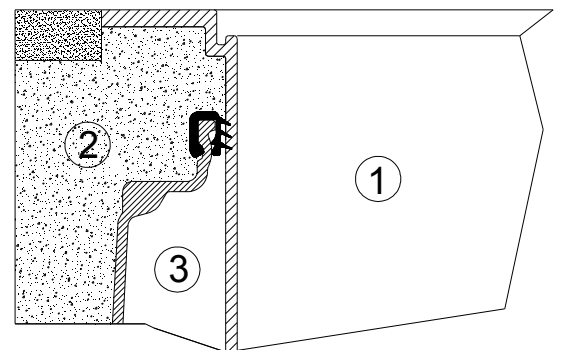

6.4 Telescopic dome shaft over which passenger cars may drive

If the tank is installed under areas used by passenger cars, the collar area of the telescope ① (colour anthracite) must be supported with concrete ④ (load class B25 = 250 kg/ m²). The layer of concrete to be installed must be at least 300 mm wide and approx. 200 mm high all around. The permitted coverage above the shoulder of the tank is min. **750 mm** and max. **1300 mm**. There are different possibilities for lengthening the tank dome (610 mm): telescopic dome shaft with cast iron lid or HGV (max. effective length 440 mm) as well as the Adapter (max. effective length 300 mm).

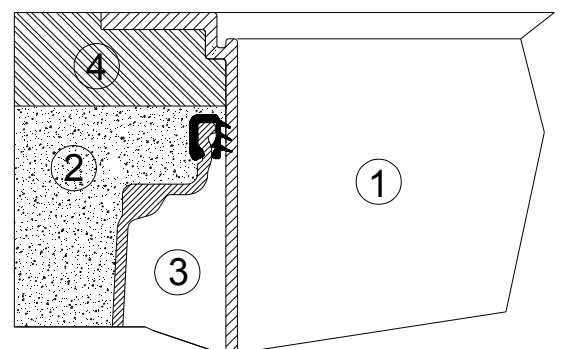

Attention: Use the cast cover under all circumstances.

6. Assembling the tank dome and telescopic dome shaft

6.5 Telescopic dome shaft for HGV loading

When installing below surfaces driven on by HGVs, the telescope is lined ① as described in 6.4. The concrete rings ⑥ (diameter 600 mm) and a cast frame ⑤ with star-shaped load distribution are then installed to support the cast cover. The cast frame must have a contact area of approx. 1 m². To extend the shaft, the telescopic dome shaft for HGV loading with class D cover, provided by the customer (max. useful length 440 mm), and the spacer (max. useful length 300 mm) can be used.

Please note: Can only be driven over with HGV, if a self-supporting, steel-reinforced concrete plate is installed!

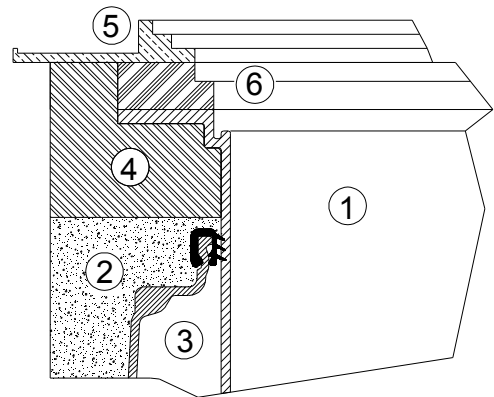

7. Assembly of the adapter

7.1 Assembling the extension

For larger coverage heights an extension is needed. To insert the extension into the tank dome, soft soap is needed. Into the highest groove of the extension the profile seal is inserted and greased generously. Afterwards push the telescopic dome shaft into the extension and adapt it to the planned area surface.

max. earth-cover 1500 mm

① Telescopic dome shaft (can be inclined by 5°)

② Extension

③ Tank dome (can be rotated by 360°)

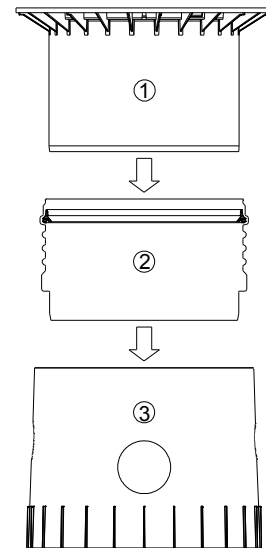

8. Platin XXL Infiltration Tank

8.1 Platin XXL Infiltration Tank

The PLATIN XXL tank is also available for using for the infiltration of rainwater. The GRAF team would be pleased to help you to determine the correct size for your building project.

Pre-filtering of the rainwater with a suitably sized filter is required for seamless operation of the Platin XXL infiltration tank. For this purpose, external pre-filters are available in the GRAF product range for cleaning and filtering rainwater up to inlet and outlet dimensions of DN300. Internal filters with connecting dimensions of up to a maximum of DN150 are also available.

Both internal and external pre-filters can be used. However, the filters must be sized correctly for the collection of dirt and coarse materials, and the emergency overflows of the filters must by-pass Platin XXL infiltration tank.

8.2 Installation and assembly

- | | |
|--|--------------------------------------|
| ① Soil | ⑤ Covering layer |
| ② Telescopic dome shaft | ⑥ Platin XXL infiltration tank |
| ③ Compacted base layer | ⑦ Concrete layer for driven-on areas |
| ④ Surround (round gravel, max. grain 8/16) | ⑧ Point drainage for infiltration |
- β --> DIN 4124 from trench depth of 1250 mm

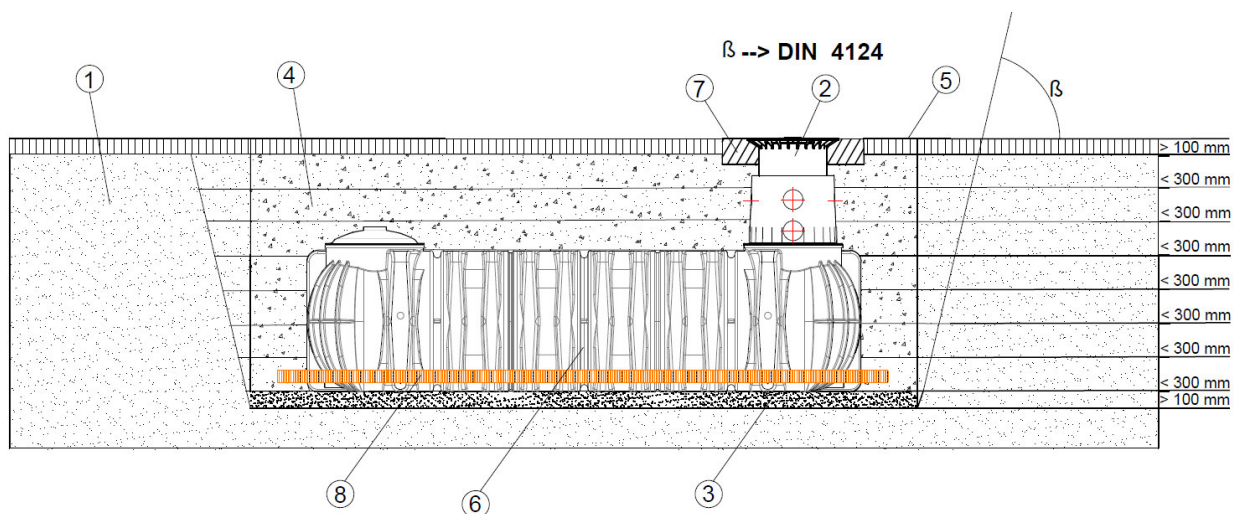

8.3 Preparing and shortening the drainage pipes

The channel drainage that is required must be cut to size from the supplied roll of drainage pipe on site. The following sections are required for assembly:

- Ⓐ 4x 0.5 m connection
- Ⓑ 2x 0.5 m connecting piece, lateral
- Ⓒ 2x longitudinal section, long side
- Ⓓ 4x drainage branches

The scope of delivery also includes four drainage branches Ⓓ for connecting the surrounding point drainage to the front end.

First the four connections to the slide-in unit Ⓐ and the two lateral connections Ⓑ are cut from the supplied roll of drainage pipe. The remainder of the roll is cut into two longitudinal sections of equal length Ⓒ.

The longitudinal pieces which are produced Ⓒ are now placed into the trench along the long side on the right and left of the Platin XXL infiltration tank.

8. Platin XXL Infiltration Tank

8.4 Assembling the drainage accessories

The Platin XXL infiltration tank is supplied from the factory with four inserted DN150 special seals on the front, lower connecting surfaces. The connections **A** are pushed into the four openings of the special seals to a depth of about 150mm. Then the drainage branches **D** can be pushed onto the protruding ends of the connections **A**. Two of the four drainage branches **D** are connected to each other laterally using the prepared connection **B**.

The ends of the laid longitudinal sections **C** are then also inserted into the drainage branches **D**. The distance between the tank and the surrounding point drainage should be about 200 – 300 mm.

- A** 4x 0.5 m connection
- B** 2x 0.5 m connecting piece, lateral
- C** 2x longitudinal section, long side
- D** 4x drainage branches

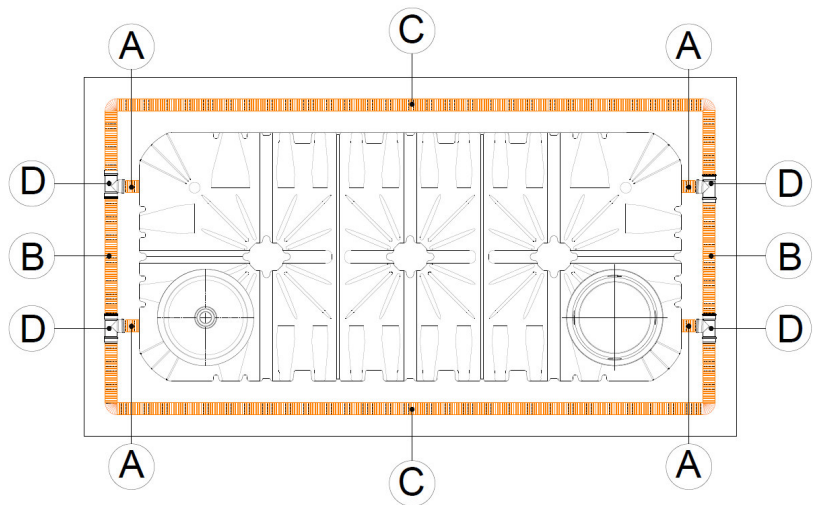

8.5 Filling

Side filling must be carried out using permeable and granular material (e.g. round-grained gravel with max. grain size of 8/16). Filling must take place in small steps, and particularly in the vicinity of the centre support columns the filling material must be properly compacted (see figure with hand tamper). Be careful to avoid damaging the tank when compacting. Mechanical compacting machines must not be used under any circumstances.

8.6 Laying connections and fitting the cover

The installation steps for laying the connections which are needed can be found in chapter 5.4. The installation of the tank dome, intermediate sections and the various covers is also described in chapters 6 & 7.

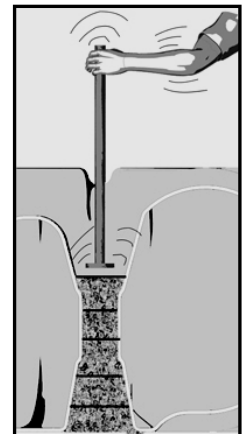

9. Inspection and servicing

The entire system must be checked for leaks, cleanliness and stability at least every three months.

The entire system should be serviced at intervals of approx. 5 years. In this case, all parts of the system must be cleaned and their function checked. Servicing should be carried out as follows:

- Drain the tank completely
- Clean surfaces and internal parts with water
- Remove all dirt from the tank
- Check that all internal parts are firmly seated.

