

Legend	
1.	GRAF Carat S 1000 Gallon Underground Tank.
2.	GRAF Optimax Pro Internal High efficiency, self-cleaning, In Tank filtration system.
3.	4" overflow drain to storm drain or other. Typically 4" PVC Sewer and Drain.
4.	1-1/4" Bulkhead Fitting for plumbing thru tank or riser assembly.
5.	115v Power supply.
6.	Overflow siphon.
7.	GRAF 1-1/4" Floating Pump Extractor with 1200 Micron Coarse Screen
8.	RainFlo 1.25 HP 115v Submersible Rainwater Pump High performance submersible rainwater pump with stainless steel base and 1-1/4" threaded inlet for use with a floating filter.
9.	4" Pipe Gasket.
10.	4" PVC from Roof Gutters and Downspouts (By Others).
11.	1 1/4" Schedule 40 PVC Pump output to use.
12.	Calming inlet to prevent the disturbance of the fine sediment layer at bottom of tank.
13.	Adjustable Riser and Childproof Lid.
14.	4" Pipe Coupler.
15.	Pump Output Line to Irrigation (By Others).
16.	Dome and Shaft Seal Gaskets.



Tank height should be set and plumbing pitched to best utilize existing grade. A site assessment should be done prior to installation to determine the optimum levels for filter and plumbing so as to provide positive drainage to tank and stormwater overflows.

USER'S Responsibility

Untreated Rainwater is NON-Potable water. Warning do not drink water supplied from RainHarvest Systems rainwater systems and related equipment. We will be happy to offer suggestions on the use of our various products either by way of printed material or through direct contact with RainHarvest Systems team members. However, since we have no control over the use of our products once they are shipped, NO WARRANTY WHETHER OF MERCHANTABILITY, FITNESS FOR PURPOSE, OR OTHERWISE is made beyond the repair, replacement, or refund of purchase price at the sole discretion of RainHarvest Systems. Users shall determine the suitability of the product for the intended application before using, and the users assume all risk and liability whatsoever in connection therewith, regardless of any team members suggestions or statements as to the application or construction. In no event shall any remedy exceed the purchase price of the product. Consult local building codes for the system use.

GRAF Optimax High efficiency, Self-Cleaning, In Tank Filtration System:

- * Filter specially developed for rain water harvesting
- * Low maintenance; self cleaning
- * Only 6.5" height offset between inlet and outlet
- * 0.35mm (.01") mesh filter
- * Transparent cover for easy maintenance
- * Optional Opticlean® Sprayhead
- * Over 95% yield
- * Self-cleaning filter
- * Max. 3,750 sq. ft. with 4" connections
- * Space saving filter technology integrated in the tank

GRAF Carat S 1000 Gallon Tank Specifications:

- 1. Variable burial depth: 30" to 42" (59" Max. with optional dome extension and "Maxi" telescopic riser).
- Unique in the world! – a global innovation: unique manufacturing process produces the highest stability due to latest techniques.
- Unique fit accuracy of the components thanks to new production process.
- Consistent quality due to TÜV safety testing and production monitoring.
- Vehicle-bearing (with telescopic cast iron manway kit). Groundwater stable up to the middle of the tank due to extremely rigid construction.
- Secure investment with market leading 15-year warranty. Made from high quality Duralene; easy to recycle.
- Can be expanded as required.

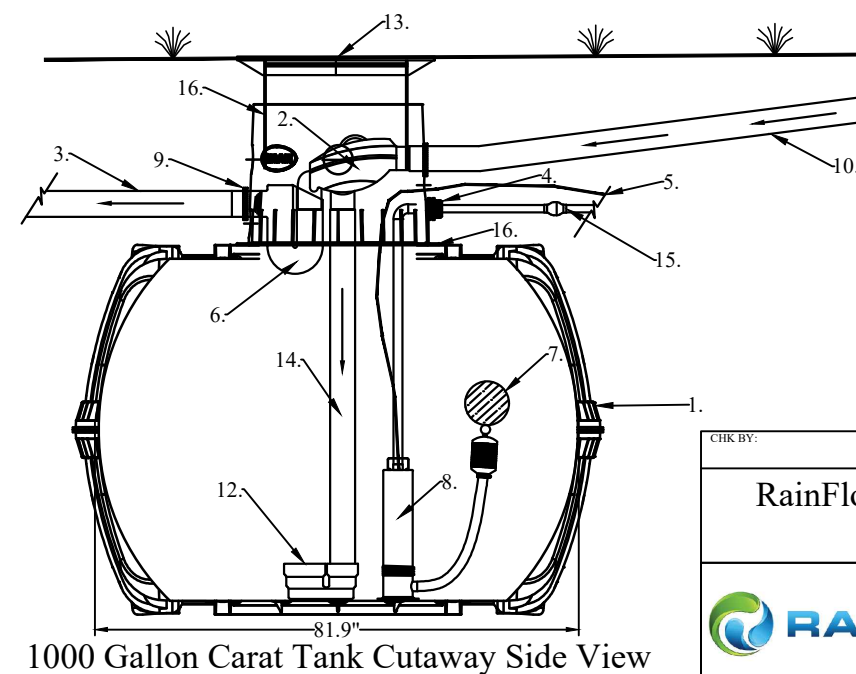
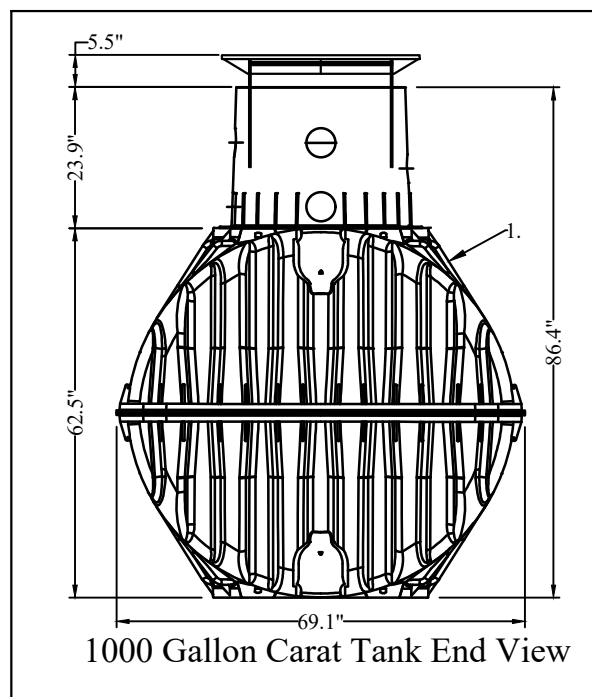

NOTE: This drawing is for illustrative purposes only. Actual systems and designs may vary. Always check with local building codes as they will apply. Electrical work to be performed by licensed professional. Points of use shall be labeled as: "Non Potable water, Do Not Drink!"

CHK BY:	APP BY:	DRAWN BY: CMG	QUOTE NO.:	SH# 1 OF 1
RainFlo 1000 IG GRAF Rainwater Collection System				
		RainHarvest Systems LLC. 4475 Alicia Lane Suite 100 Cumming, GA 30028 Tel: 770-889-2533 Fax: 770-889-2577		